



CMM BRIDGE BENCHMARK

06.05.05 MOT

HALF-GANTRY TYPE CNC COORDINATE
MEASURING MACHINE



CMM BRIDGE | BENCHMARK

STRUCTURE

Coordinate Measuring Machine, CNC, with aluminum alloy mobile half-gantry structure on granite table machine base.

Surface Plate: granite table with integrated guide-ways with flatness to DIN876/III and M8 threaded insert grid.

CMM Basement

BENCHMARK: STD CMM Basement

OPTION: CNC controller & PC integrated

Guideways

X axis machined into granite table (left) and micromachined and hard anodized alloy extrusions (right).

Y axis micro-machined and hard anodized alloy extrusions

Z axis micro-machined and hard anodized alloy extrusions

Drive Method: NC drive via DC motors with zero hysteresis friction drive on steel bar to all axes

Bearing System: air bearings to all axes

Measuring System: high resolution (0,1µm) free floating linear scales mounted in carriers

Motion Control: DC servomotor on all axes

Counterbalance: adjustable pneumatic on Z ram

Thermal compensation: multi-sensors temperature compensation system (total 4 sensors) in Option.

OPTION

Active vibration insulating system
Multi-wire cable

POWER SUPPLY

Power supply voltage:

230 V ± 10%; 50 Hz ± 2% single phase

115 V ± 10%; 60 Hz ± 2% single phase

AIR SUPPLY

Air Consumption:

90 NI/min

Minimum Air Supply:

5 Bar (71PSI)

PROBING SYSTEM

Manual Probe Head:

TPC3, MIH, MH20, MH20i, MH8, RTP20

Motorized Probe Head:

PH10T, PH10M, PH20

Point-to-point Trigger Probe:

TP20, TP200, TP200B

Stylus and Probe Changer:

Fully automated stylus and probe changers

ENVIRONMENT

Temperature Range for Metrological Specification:

Ambient Temperature Range: 18 ÷ 22 °C

Max. gradient for hour: 0,5 °K/h

Max. gradient for day: 2,0 °K/24h

Max. gradient in space: 0,5 °K/m

Operating Temperature:

15 ÷ 35 °C

Relative Humidity:

40 ÷ 80 % (non condensing)

Acceptable Vibrations:

(vibration acceleration between peaks)

30 mm/s² from 1 to 10 Hz

15 mm/s² from 10 to 20 Hz

50 mm/s² from 20 to 100 Hz

STROKES, DIMENSIONS, WEIGHTS

BENCHMARK is also available w/o intergrated controller and mobile arm. Need a UNITABLE desk (1200 x 800 x 715 mm) for controller and PC/Monitor/keyboard.
 BENCHMARK è anche disponibile senza controllo integrato e braccio articolato.
 Necessita di scrivania UNITABLE (1200 x 800 x 715 mm) per controllo, PC, video e tastiera.

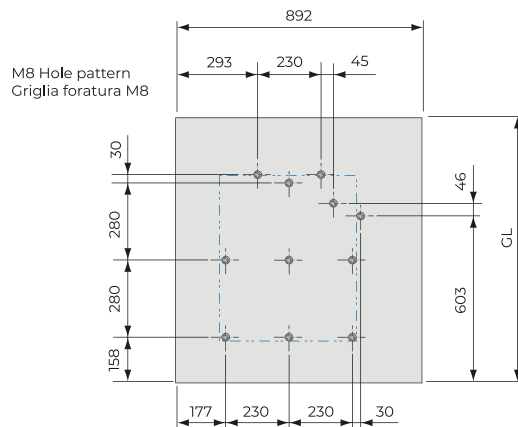
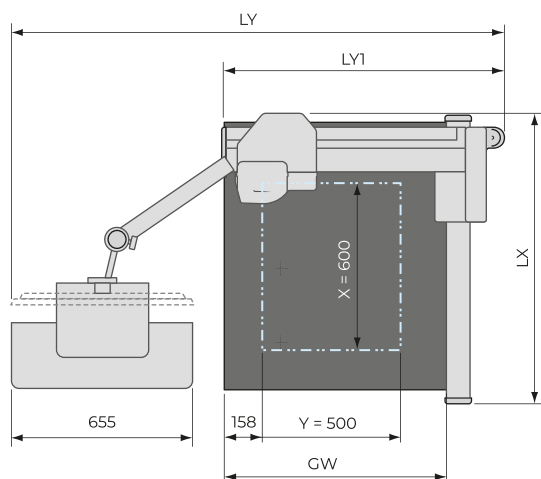
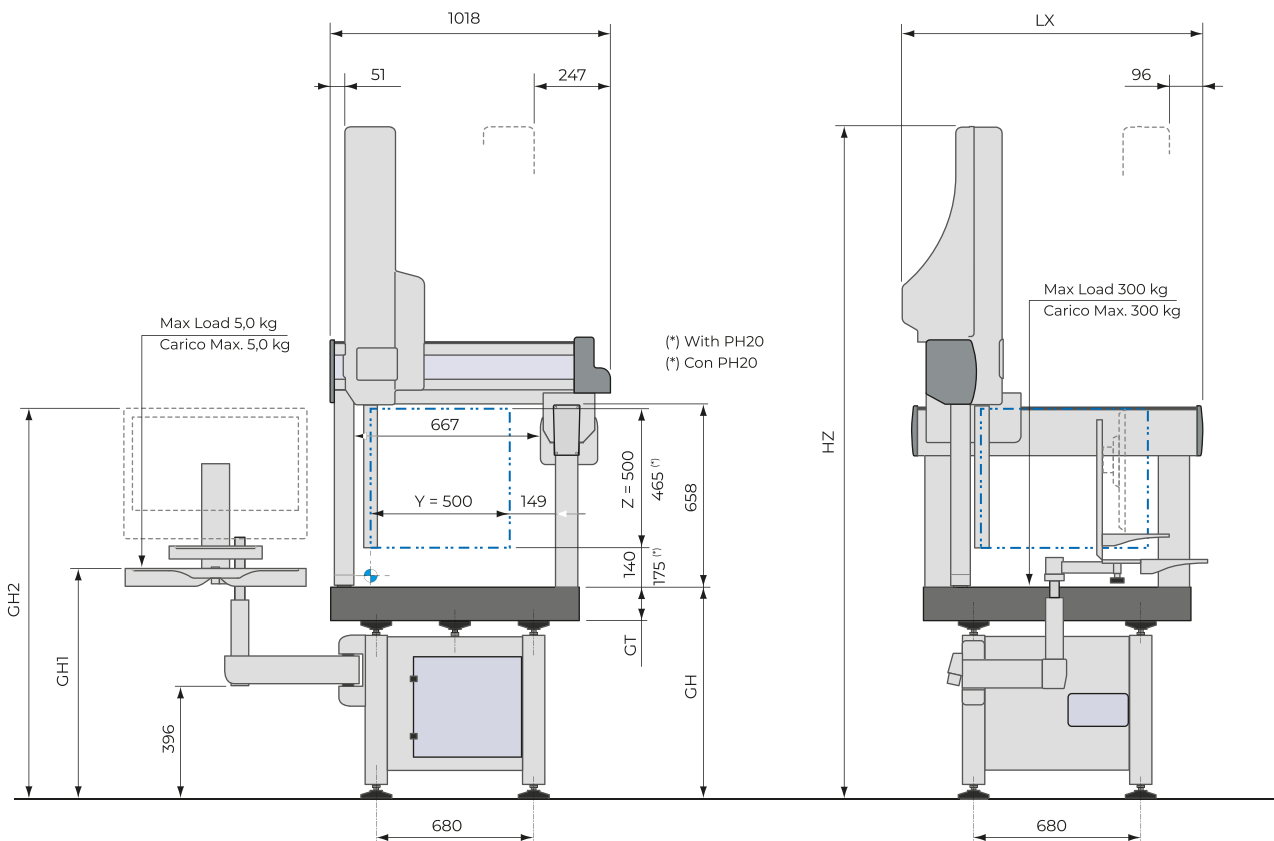
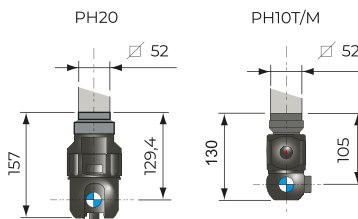

Models	Measuring Strokes			Overall Dimensions				Surface Plate						Weights	
	X	Y	Z ^(a)	LX	LY	LY1 ^(c)	HZ	GH	GT	GL	GW	GH1	GH2	Max. Part Weight	Machine Weight ^(b)
	[mm]			[mm]				[mm]						[kg]	
06.05.05	600	500	500	1066	1800÷1930	1018	2392	750	100	960	803	800÷1200	1395÷1825	300	435

^(a)With PH20 Probe Head Z Measuring stroke will be reduced to 470 mm

^(b)Weigh includes CMM, Basement. Weight does not include Control and PC, keyboard and Video Terminal (approx. 20 kg)

^(c)BENCHMARK w/o integrated control and articulated arm - Need a UNITABLE desk for controller and PC

CMM BENCHMARK SPECIFICATIONS

Models	Specification according to UNI EN ISO 10360-2:2010				Max. 3D Pos. Speed [mm/s]	Max. 3D Acc. [mm/s ²]
	MOTORIZED					
	MH20i/PH10T/M/PH20-TP20		PH10T/M-TP200			
	⁽¹⁾ MPE _{E0/150}	⁽²⁾ MPL _{RO}	⁽¹⁾ MPE _{E0/150}	⁽²⁾ MPL _{RO}		
06.05.05	2,7 + 3,0 L/1000	2,5	2,5 + 3,0 L/1000	2,5	500	1500

Performance data are only valid if the following specifications are met:

- MPE_{E0}/MPE(PFTU)/MPL_{RO}: PH10M/PH10T/PH20/TP20/TP200: tip diameter Ø 4 mm, stylus length 10 mm.
- MPE_{E150}: PH10M/TP20/TP200: tip diameter Ø 4 mm, stylus length 40 mm.
PH20/MH20i: EM1 STDF, tip diameter Ø 4 mm, stylus length 20 mm.
PH10T: PEL2, tip diameter Ø 4 mm, stylus length 10 mm
- L = measuring length in mm

- Ambient temperature Range:

T1: 18 ÷ 22 °C; Max. Gradients: 1,0 °C/h - 2,0 °C/24h - 1,0 °C/m

⁽¹⁾ Maximum Permissible Error of indication for size measurement according UNI EN ISO 10360-2:2010

⁽²⁾ Maximum Permissible Probing Error according UNI EN ISO 10360-2:2010
⁽³⁾ Maximum Permissible Shape error with single stylus according UNI EN ISO 10360-5:2010

CMM BENCHMARK PERFORMANCE VERIFICATION

MPE_{E0}: Maximum Permissible Error on length measurement with standard probe OFFSET

Measurement of a set of 5 sizes, taken through two opposite probing points on two nominally parallel planes. The sizes are positioned with direction on the 4 volume diagonals and in 3 different positions chosen by the customer (or along the axes according to the standard) in the measurement volume. Each size is measured 3 times for a total of 105 measurements. All 105 measurements (100%) must be within the specified MPE_{E0}.

MPE_{E150}: Maximum Permissible Error on length measurement with probe OFFSET 150mm.

Measurement of 1 set of 5 different sizes in 2 diagonal positions on the XZ or YZ plane with a probe OFFSET of 150mm. All 30 measurements must be less than the Maximum Permissible Error MPE_{E150}

MPL_{RO}: Maximum Permissible Repeatability Limit

Evaluation of the 35 repeatability values calculated from the difference between the maximum and minimum values of the three different measurements made on the same length size on each of the 5 samples in each of the 7 positions. Each of these 35 R_o value must be less than the maximum permissible limit MPL_{RO}

MPE (PFTU): Maximum Permissible Single Stylus Form Error

A reference sphere is measured with 25 equally distributed probings, estimate of the deviation in the shape of the sphere, obtained as a dispersion band of the 25 polar rays. The probing performance shall be verified in one position, placed in the middle of the CMM measure volume. Calculation of the Gaussian sphere using the 25 measures. Calculation of the radial distances R, for each of the 25 measured points. Calculation of the PFTU point gripping error, as dispersion band of the 25 radial distances, Rmax-Rmin. The PFTU error must be within the MPE(PFTU).



TouchDMIS